

---

# Industrial System Protection

Course No: D04-003

Credit: 4 PDH

---

Velimir Lackovic, Char. Eng.

---



Continuing Education and Development, Inc.  
22 Stonewall Court  
Woodcliff Lake, NJ 07677

P: (877) 322-5800  
[info@cedengineering.com](mailto:info@cedengineering.com)

---

## **INDUSTRIAL SYSTEM PROTECTION**

Development of industrial and commercial electrical power systems has also introduced the requirements for their improved reliability. The possible outage time costs have also dramatically increased. The introduction of automation systems into industry and commerce requires application of advanced power system automation in order to enhance overall reliability and efficiency. Careful attention has to be given to the protection and control of industrial electrical supply systems. Many technologies that have been developed for EHV electrical systems may be used in lower voltage systems but usually on a reduced scale. Nevertheless, industrial electrical systems have many particular issues that need special attention and the development of custom solutions. Many industrial systems have their own generation. Sometimes it is used only in emergency situations, supplying a limited number of buses and with limited capacity. This design is frequently used to ensure safe shutdown of process plant and personnel safety. However, in some plants, processes allow generation of a substantial quantity of electricity, allowing surplus export to the grid. Industrial plants that operate power generation in parallel with the utility grid are usually referred to as cogeneration or embedded generation. Particular protection design may be needed for the point of common coupling between the private and utility grid. Industrial systems usually comprise many cable feeders and transformers and special protection arrangements may be also required for them.

## **BUSBAR ARRANGEMENT**

The system busbar arrangement is apparently very important, and it can be quite complex for very large industrial systems. Nevertheless, in most industrial systems a single busbar divided into sections by a bus-section circuit breaker is typical. This configuration is shown in Figure 1. Main and standby drives for particular process equipment will be supplied from switchboard separate sections, or sometimes from different switchboards.

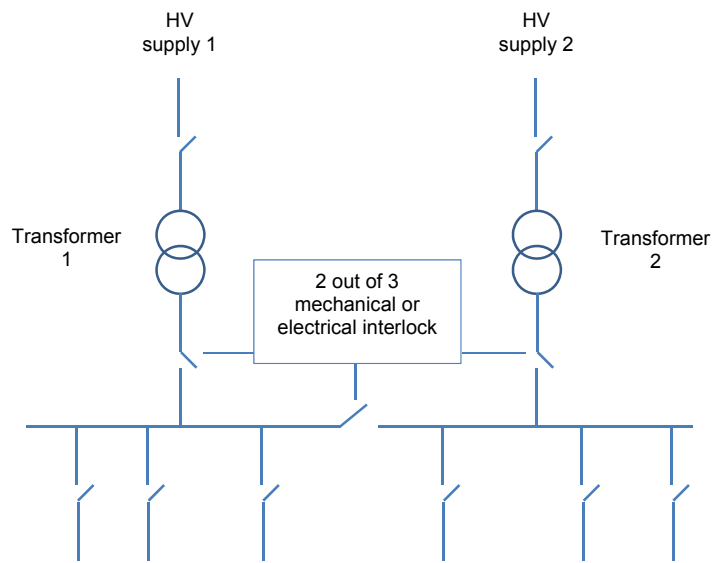

Figure 1. Common switchboard arrangement for an industrial plant

The main system design condition is that electrical network single outages within the plant will not cause simultaneous loss of both the main and standby drives. Analyzing a medium sized industrial supply system, presented in Figure 2 it will be noted that not only duplicate supplies and transformers are used, but also few important loads are separated and supplied from 'Essential Services Board(s)' (usually known as 'Emergency' boards). This allows maximum utilization of the standby generator equipment. A standby generator is typically of the turbocharged diesel-driven type. On loss of incoming supply detection at any switchboard with an emergency section, the generator is automatically started. The adequate circuit breakers will close once the generator is up to speed and rated voltage to recover supply to the Essential Services affected switchboard sections. For a common diesel generator set, the emergency supply would be available within 10-20 seconds from the start sequence command being released.



This will cover process drives that are needed for safe shutdown, venting systems, UPS loads supplying emergency lighting, process control computers, etc. The emergency generator may vary in size from a single unit rated 20-30kW in a small plant up to several units of 2-10MW in a large oil refinery. Big financial trading institutions may also have standby power demands of few MW to keep computer systems.

## **DISCRIMINATION**

Protection equipment operates in conjunction with switchgear. For a common industrial system, feeders and plant will be typically protected by different circuit breakers and by fused contactors. Circuit breakers will have their overcurrent and ground fault relays. A contactor may also be installed with a protection device (e.g. motor protection), but associated fuses are supplied to break fault currents surpassing the contactor interrupting capability. The rating of fuses and selection of protection relay settings is completed to ensure that discrimination is accomplished – i.e. the ability to select and isolate only the faulty part of the system.

## **HRC FUSES**

The protection element nearest to the actual point of power utilization is probably the fuse or a system of fuses. It is important that attention is provided to the correct fuse application. The HRC fuse is a key fault clearance device for industrial and commercial system protection. It can be installed in a distribution fuse board or as part of a contactor or fuse-switch. The second is looked at as a crucial part of LV circuit protection, combining safe circuit making and breaking with an isolating capability accomplished in conjunction with the HRC fuse reliable short circuit protection. Fuses combine the characteristics of economy and reliability. These factors are vital for industrial applications. HRC fuses stay consistent and stable in their breaking characteristics without calibration and maintenance. This is one of the major factors for keeping fault clearance discrimination. Lack of discrimination through improper fuse grading will end in unnecessary supply disconnection. However, if both the major and minor fuses are properly designed HRC devices this will not endanger staff or cables associated with the plant.

## FUSE CHARACTERISTICS

The time needed for melting the fusible element is dependent on the current magnitude. This time is known as the fuse 'pre-arcing' time. Element vaporization happens on melting and there is fusion between the vapor and the filling powder resulting in quick arc extinction. Fuses have a valuable feature known as 'cut-off'. It is presented in Figure 3. When an unprotected circuit is exposed to a short circuit fault, the r.m.s. current increases towards a 'prospective' (or maximum) value. The fuse typically breaks the short circuit current before it can reach the prospective value. This happens in the first quarter to half cycle of the short circuit. The increasing current is broken by the fusible element melting, subsequently dying away to zero during the arcing period.

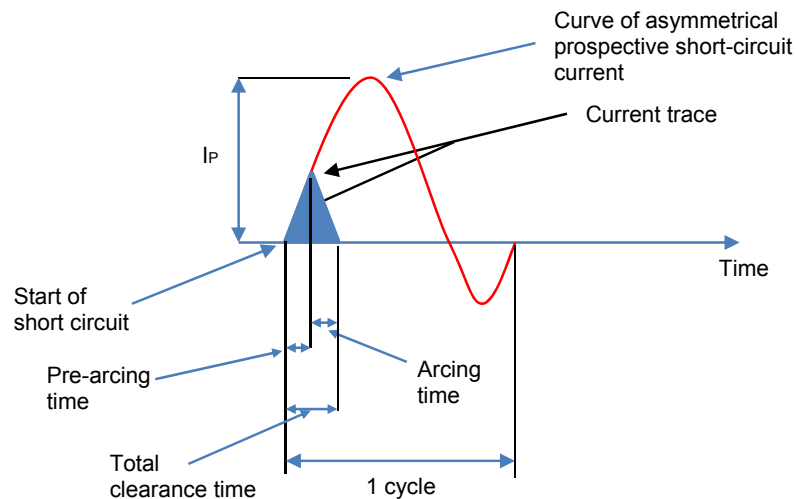

Figure 3. HRC fuse cut-off characteristic

Since the electromagnetic forces on busbars and connections conducting short circuit current are proportional to the square of the current, it will be noted that 'cut-off' significantly decreases the mechanical forces generated by the fault current and which may distort the busbars and connections if not properly rated. A common example of 'cut-off' current feature is presented in Figure 4. It is possible to use this feature during the project design stage to select equipment with a lower fault withstand rating downstream of the fuse. This may save money, but adequate documentation and maintenance controls are needed to ensure that only replacement fuses with very

similar features are used throughout the plant lifetime – otherwise a safety hazard may happen.

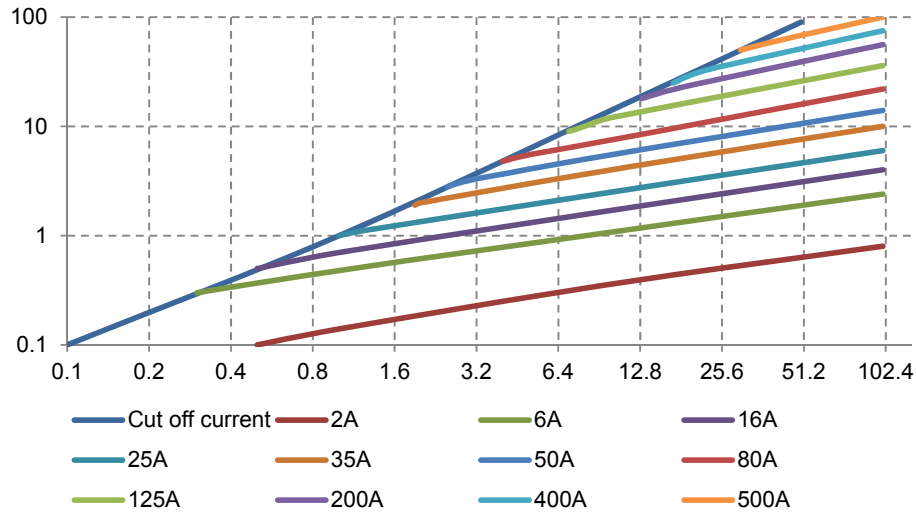

Figure 4. Common fuse cut-off current features

## DISCRIMINATION BETWEEN FUSES

Fuses are typically installed in series and it is vital that they are able to discriminate with each other at all current levels. Discrimination is achieved when the bigger ('major') fuse stays unaffected by fault currents that are cleared by the smaller ('minor') fuse. The fuse operating time can be looked at in two parts:

- the time needed for fault current to melt the element, known as the 'pre-arcing time'
- the time needed by the arc generated inside the fuse to extinguish and isolate the circuit, known as the 'arcing time'

The total energy released in a fuse during its operation consists of 'pre-arcing energy' and 'arc energy'. The values are typically shown in terms of  $I^2t$ , where  $I$  is the current flowing through the fuse and  $t$  is the time in seconds. Presenting the quantities in this way provides an assessment of the heating effect that the fuse imposes on related equipment during its operation under fault conditions. To achieve positive discrimination between fuses, the total  $I^2t$  value of the minor fuse must not surpass the pre-arcing  $I^2t$  value of the major fuse. In reality, this means that the major fuse will

have to have a rating considerably higher than that of the minor fuse, and this may increase discrimination problems. Commonly, the major fuse must have a rating of at least 160% of the minor fuse for discrimination to be achieved.

### **PROTECTION OF CABLES BY FUSES**

PVC cable can be loaded to its full nominal rating only if it has 'close excess current protection'. This degree of protection can be provided by means of a fuse link having a 'fusing factor' not surpassing 1.5, where:

- Fusing factor = Minimum Fusing Current/Current Rating Cables made using other insulating materials (e.g. paper, XLPE).

### **AMBIENT TEMPERATURE EFFECT**

High ambient temperatures can affect HRC fuses capability. Most fuses are suited for application in ambient temperatures up to 35°C, but for some fuse ratings, derating may be required at higher ambient temperatures. Manufacturers' documentation should be consulted for the de-rating factors.

### **MOTOR PROTECTION**

The manufacturers' documentation should also be consulted when fuses are to be used for motor circuits. In this case, the fuse gives short circuit protection but must be chosen to withstand the starting current (roughly up to 8 times full load current), and also continuously transfer the normal full load current without deterioration. Tables of recommended fuse sizes for both 'direct on line' and 'assisted start' motor configurations are typically provided.

### **INDUSTRIAL CIRCUIT BREAKERS**

Some industrial power system parts are most effectively protected by HRC fuses, but the replacement of blown fuse links can be especially difficult in some situations. In these plants, circuit breakers are used instead. The breaker is required to successfully break the maximum possible fault current without damage to itself. In addition to fault current interruption, the breaker must rapidly release the resulting ionized gas away from the breaker contacts, to stop arc re-striking. The breaker, its cable or busbar



connections, and the breaker housing, must all be made to withstand the mechanical stress resulting from the magnetic fields and internal arc gas pressure generated by the highest levels of fault current. The circuit breaker types that are most frequently installed in industrial system are described in the following paragraphs.

### **MINIATURE CIRCUIT BREAKERS (MCBS)**

MCBs are small circuit breakers, both in physical size but more importantly, in ratings. The basic single pole element is a small, manually closed, electrically or manually opened switch planed in a moulded plastic casing. They are suited for use on 230V AC. single-phase/400V AC three-phase systems and for DC auxiliary supply systems, with current ratings of up to 125A. Thermal element is contained within each unit in which a bimetal strip will operate the switch when excessive current goes through it. This element works with a predetermined inverse-time/current characteristic. Greater currents, commonly those surpassing 3-10 times rated current, trip the circuit breaker without intentional delay by actuating a magnetic trip overcurrent element. The MCB operating time characteristics are not adjustable. European Standard EN 60898-2 determines the instantaneous trip characteristics, while the manufacturer can define the inverse time thermal trip characteristic. Hence, a common tripping characteristic does not exist. The maximum AC breaking current allowed by the standard is 25kA. Single-pole elements may be mechanically coupled in groups to make 2, 3 or 4 pole units, when needed. The available ratings make MCBs appropriate for industrial, commercial or domestic installations, for protecting equipment such as cables, lighting and heating circuits, and also for the low power motor circuits control and protection. They may be installed instead of fuses on individual circuits, and they are typically 'backed-up' by a device of higher fault interrupting capacity. Different accessory units, such as isolators, timers, and under-voltage or shunt trip release elements may be combined with an MCB to suit the particular circuit. When personnel or fire protection is needed, a residual current device (RCD) may be combined with the MCB. The RCD contains a miniature core balance current transformer that embraces all of the phase and neutral conductors to give sensitivity to ground faults within a common range of 0.05% to 1.5% of rated current, dependent on the installed RCD. The core balance CT supplies a common magnetic trip actuator for the MCB assembly. It is also feasible to get current-limiting MCBs. These types open prior to the prospective fault current

being achieved. Hence, they have similar properties to HRC fuses. It is claimed that the additional initial cost is outweighed by lifetime savings in replacement costs after a fault has happened, plus the benefit of providing improved protection against electric shock. As a result of the enhanced safety given by MCBs equipped with an RCD device, they are tending to replace fuses, particularly in new installations.

### **MOULDED CASE CIRCUIT BREAKERS (MCCBS)**

These circuit breakers are very similar to MCBs but have the following crucial differences:

- the maximum ratings are greater, with voltage ratings up to 1000V AC/1200V DC. Current ratings of 2.5kA continuous/180kA r.m.s break can be accomplished, dependent upon power factor.
- the breakers are bigger, commensurate with the level of ratings. Even though available as single, double or triple pole units, the multiple pole units have a common housing for all the poles. Where installed, the switch for the neutral circuit is typically a separate device, coupled to the multi-pole MCCB.
- the operating levels of the magnetic and thermal protection devices may be adjustable, especially in the bigger MCCBs
- because of their bigger ratings, MCCBs are typically installed in the power distribution system closer to the power source than the MCBs
- the adequate European specification is EN 60947-2. Attention must be taken in the MCCB short-circuit ratings.

MCCBs are provided with two breaking capacities, the higher of which is its ultimate breaking capacity. The importance of this is that after breaking such a current, the MCCB may not be fit for extended use. The lower, or service, short circuit breaking capacity allows extended use without further detailed examination of the device. The standard allows a service breaking capacity of as little as 25% of the ultimate breaking capacity. While there is no problem to use of MCCBs to break short-circuit currents

between the service and ultimate values, the inspection needed after such a trip decreases the device usefulness. Clearly, it is also difficult to decide if the fault current magnitude was in excess of the service rating. Some MCCBs are equipped with microprocessor-controlled programmable trip features providing a wide range of such characteristics. Time-delayed overcurrent features may not be the same as the standard characteristics for dependent-time protection described in IEC 60255-3. Therefore, discrimination with other protection must be carefully considered. There can be issues where two or more MCBs or MCCBs are connected in series, as obtaining selectivity between them may be difficult. There may be a demand that the major device should have a rating of  $k$  times the minor device to allow discrimination. The manufacturer should be consulted for  $k$  values. Careful examination of manufacturers' documentation is always needed at the design stage to determine any such limitations that may be imposed by MCCB particular makes and types.

### **AIR CIRCUIT BREAKERS (ACBS)**

Air circuit breakers are typically encountered on industrial systems rated at 3.3kV and below. Modern LV ACBs can be found in current ratings of up to 6.3kA with maximum breaking capacities in the range of 85kA-120kA r.m.s., depending on system voltage. This breaker type functions on the principle that the arc generated when the main contacts open is controlled by directing it into an arc chute. In this case, the arc resistance is increased and the current is decreased to the point where the circuit voltage cannot keep the arc. Therefore the current decreases to zero. To help in the quenching of low current arcs, an air cylinder may be connected to each pole to direct a blast of air across the contact faces as the breaker opens. This will also reduce contact erosion. Industrial air circuit breakers are typically withdrawable and are made with a flush front plate. Therefore, they are ideal for inclusion together with fuse switches and MCBs/MCCBs in modular multi-tier distribution switchboards. This approach helps to maximize the number of circuits within a given floor area. Older types using a manual or dependent manual closing mechanism are considered as a safety hazard. This arises under conditions of closing the CB when a fault exists on the circuit being controlled. During the close-trip service, there is a danger of arc egress from the CB casing, with a risk of injury to the operator. Such types should be replaced with modern equivalents. ACBs are typically equipped with integral

overcurrent protection, therefore avoiding the need for separate protection elements. Nevertheless, the operating time characteristics of the integral protection are typically designed to make discrimination with MCBs/MCCBs/fuses easier. Therefore, they may not be in line with the standard dependent time characteristics presented in IEC 60255-3. Hence, co-ordination problems with discrete protection relays may still happen, but modern numerical protection relays have more flexible characteristics to alleviate such problems. ACBs will also have facilities for accepting an external trip signal, and this can be used in conjunction with an external protection relay. Figure 5 presents the common tripping characteristics.

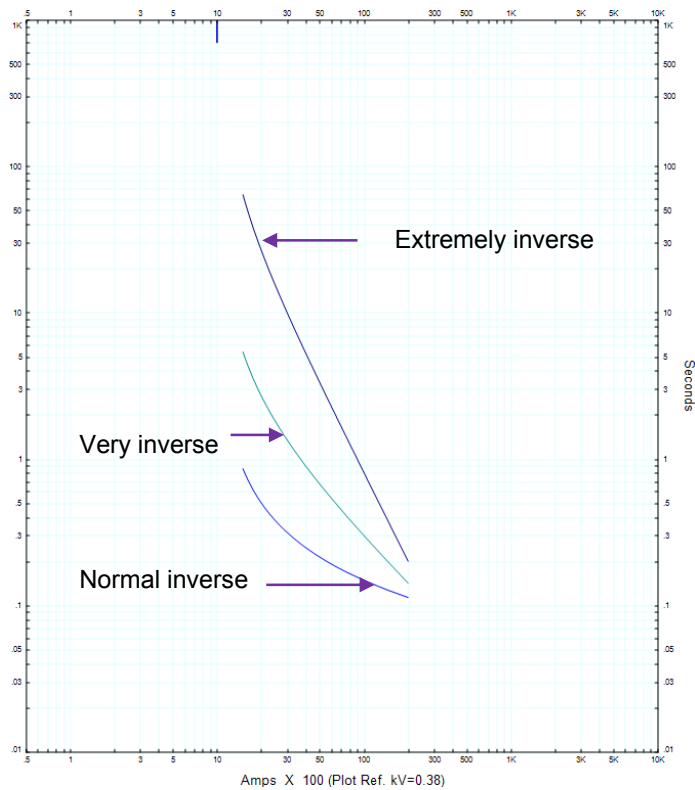

Figure 5. Common ACB tripping characteristics

## OIL CIRCUIT BREAKERS (OCBS)

Oil circuit breakers have been popular for many years for industrial supply systems at voltages of 3.3kV and above. They are found as both 'bulk oil' and 'minimum oil' models. Their only major difference is the volume of oil in the tank. In this breaker type, the main contacts are placed in an oil filled tank, with the oil acting as the both the insulation and the arc-quenching medium. The arc generated during contact

separation under fault conditions creates dissociation of the hydrocarbon insulating oil into hydrogen and carbon. The hydrogen extinguishes the arc. The generated carbon mixes with the oil. Since the carbon is conductive, the oil must be replaced after a prescribed number of fault clearances, when the contamination degree reaches an unacceptable level. Because of the fire risk involved with oil, precautions such as the construction of fire/blast walls may have to be taken when OCBs are used.

### **VACUUM CIRCUIT BREAKERS (VCBS)**

In recent years, vacuum circuit breakers, along with CBs using SF<sub>6</sub>, have replaced OCBs for new installations in industrial/commercial systems at voltages of 3.3kV and above. Compared with oil circuit breakers, vacuum breakers do not introduce fire risk and they have high reliability with long maintenance free periods. A variation is the vacuum contactor with HRC fuses, used in HV motor starter applications.

### **SF<sub>6</sub> CIRCUIT BREAKERS**

In some countries, circuit breakers with SF<sub>6</sub> gas as the arc quenching medium are preferred to VCBs as the replacement for air- and oil-insulated CBs. Some modern switchgear cubicles types allow the installation of either VCBs or SF<sub>6</sub>- insulated CBs according to customer demands. Ratings of up to 31.5kA r.m.s. fault break at 36kV and 40kA at 24kV are common. SF<sub>6</sub>-insulated CBs also have benefits of reliability and maintenance intervals compared to air- or oil-insulated CBs. They are of similar size to VCBs for the same rating.

### **PROTECTION RELAYS**

When the circuit breaker does not have integral protection, then an appropriate external relay will have to be used. For an industrial system, the typical protection relays are time-delayed overcurrent and ground fault relays.

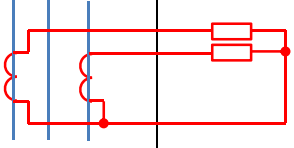
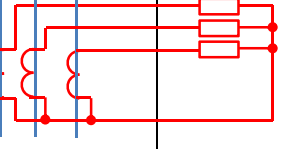
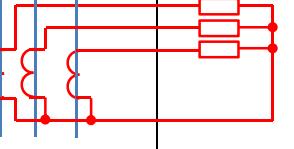
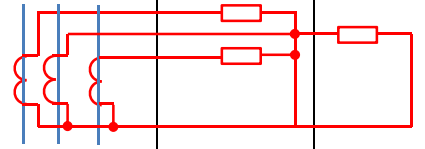
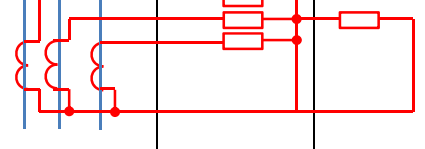
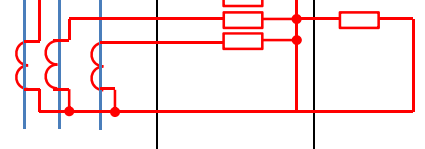
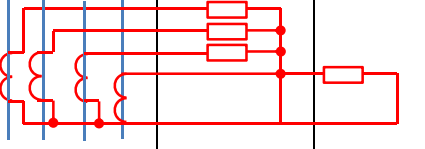
	CT connections	Phase elements	Residual current elements	System	Fault type	Notes
(a)	A B C 			3Ph.3W	Line-line	Peterson coil and unearthed systems
(b)	A B C 			3Ph.3W	(i)Line-line (ii)Line-ground	
(c)	A B C 			3Ph.4W	(i)Line-Line (ii)Line-ground (iii)Line-neutral	Ground fault protection only if ground fault current is not less than twice primary operating current
(d)	A B C 			3Ph.3W	(i)Line-Line (ii)Line-ground	Phase elements must be in same phases at all stations. Ground fault settings may be less than full load
(e)	A B C 			3Ph.3W	(i)Line-line (ii)Line-ground	Ground fault settings may be less than full load
(f)	A B C 			3Ph.4W	(i)Line-Line (ii)Line-ground (iii)Line-neutral	Ground fault settings may be less than full load but must be greater than largest Ph.-N load
(g)	A B C N 			3Ph.4W	(i)Line-line (ii)Line-ground (iii)Line-neutral	Ground fault settings may be less than full load

	CT connections	Phase elements	Residual current elements	System	Fault type	Notes
(h)				3Ph.3W Or 3Ph.4W	(i)Line-ground	Ground fault settings may be less than full load
Ph. – phase, W – wire, E – earth, N – neutral						

Figure 6. Overcurrent and ground fault relay connections

Typically, for three wire systems, overcurrent protection relays have been applied to two phases only for relay element economy. Even up until the last generation of static protection relays, economy was still a consideration in terms of the number of analogue current inputs that were provided. Two overcurrent devices can be installed to detect any interphase short circuit, so it was conventional to use two elements on the same phases at all relay locations. The phase CT residual current connections for ground fault relay element are unaffected by such convention. Figure 6 presents the possible relay arrangements and settings limitations.

## CO-ORDINATION ISSUES

There are a number of issues that typically happen in industrial and commercial networks. They are covered in the following paragraphs.

### GROUND FAULT PROTECTION WITH RESIDUALLY-CONNECTED CTS

For four-wire arrangements, the residual connection of three phase CTs to ground fault relay element will provide ground fault protection, but the ground fault relay element must be set above the highest single-phase load current to avoid nuisance tripping. Harmonic currents (which may sum in the neutral conductor) may also end in spurious tripping. The ground fault relay element will also react to a line-neutral fault

for the line that is not covered by an overcurrent element where only two overcurrent elements are used. Where it is needed that the ground fault protection responds only to ground fault current, the protection device must be residually connected to three phase CTs and to a neutral CT or to a core balance CT. In this situation, overcurrent protection must be applied to all three lines to ensure that all line-neutral faults will be discovered by overcurrent protection. Installing a CT in the neutral grounding connection to drive ground fault protection relay provides ground fault protection at the source of supply for a 4- wire system. If the neutral CT is omitted, neutral current is seen by the relay as ground fault current and the relay setting would have to be increased to stop tripping under normal load conditions.

When the ground fault protection relay is driven from residually connected CTs, the protection relay current and time settings must be such that that the protection will be stable during the passage of transient CT spill current through the protection relay. Such spill current can run in the case of transient, asymmetric CT saturation during the passage of offset fault current, inrush current or motor starting current. The nuisance tripping risk is higher with the deployment of low impedance electronic protection relays rather than electromechanical ground fault relays which presented major relay circuit impedance. Energizing a protection relay from a core balance type CT typically enables more sensitive settings to be obtained without the nuisance tripping risk with residually installed phase CTs. When this method is used in a four-wire system, it is mandatory that both the line and neutral conductors are passed through the core balance CT aperture. For a 3-wire system, attention has to be taken with the cable sheath arrangement, otherwise cable faults involving the sheath may not end in relay operation (Figure 7.).

#### **FOUR-WIRE DUAL-FED SUBSTATIONS**

The co-ordination of ground fault relays that are used to protect four-wire systems demands special consideration in the case of low voltage, dual-fed arrangements. Problems in reaching optimum protection for typical arrangements are presented below.



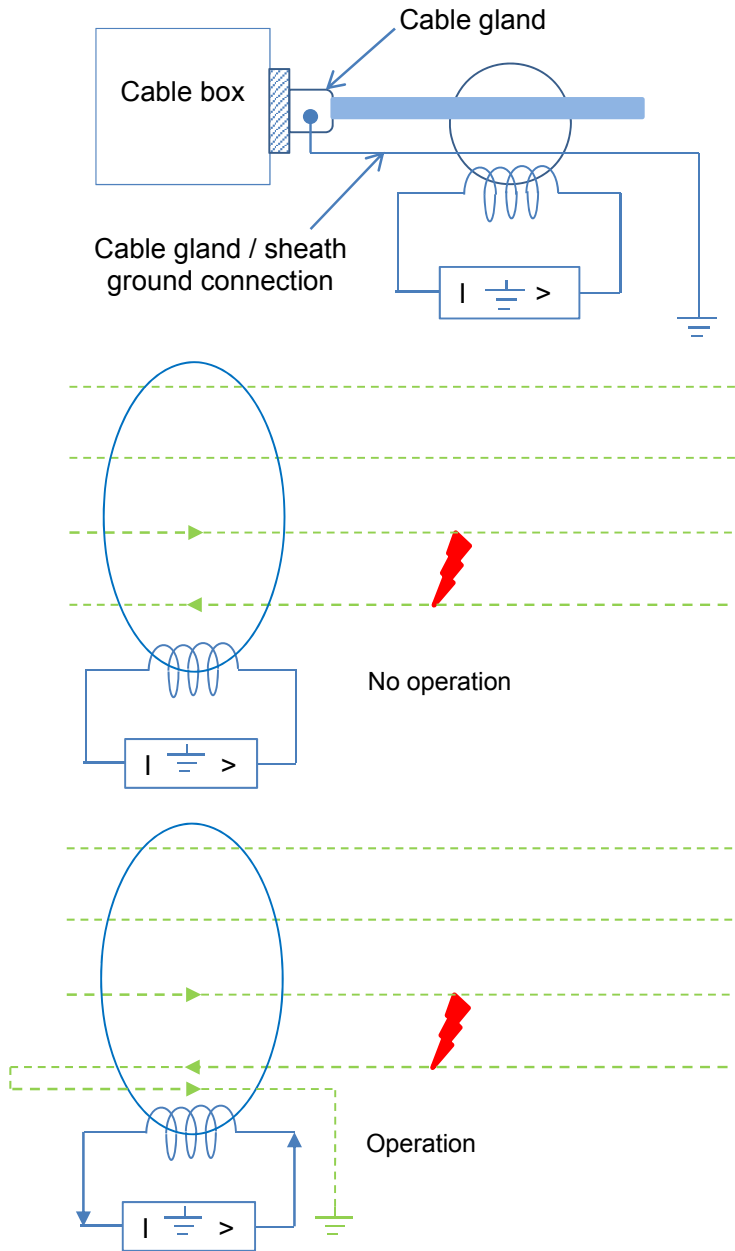

Figure 7. CBCT connection for four-wire system (a) Incorrect installation (b) Correct installation

### USE OF 3-POLE CBS

When both neutrals are grounded at the transformers and all circuit breakers are of the 3-pole type, the neutral busbar in the switchgear forms a double neutral to ground connection, as presented in Figure 8. In the case of an uncleared feeder ground fault or busbar ground fault, with both the incoming supply breakers closed and the bus

section breaker open, the ground fault current will split between the two ground connections. Ground fault relay  $R_{E2}$  may operate, tripping the supply to the healthy section of the switchboard as well as relay  $R_{E1}$  tripping the supply to the faulted section.

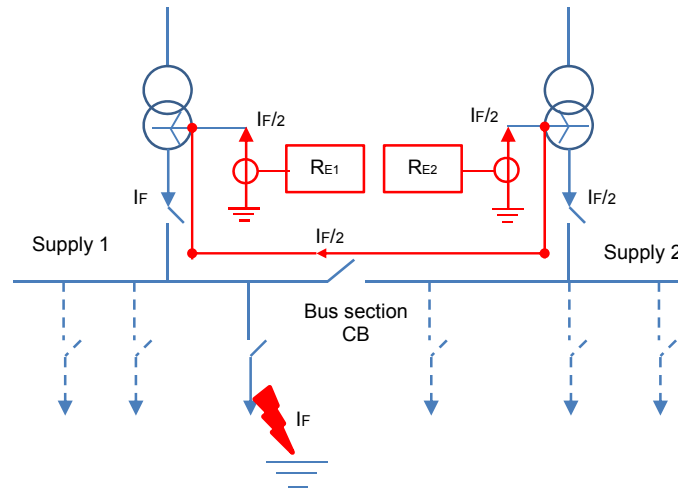

Figure 8. Dual fed four-wire systems: use of 3-pole CBs

In the case, only one incoming supply breaker is closed, the ground fault relay on the energized side will detect only a proportion of the fault current running in the neutral busbar. This not only significantly increases the relay operating time but also decreases its sensitivity to low-level ground faults. The solution to this problem is to use 4-pole CBs that switch the neutral as well as the three phases. Then there is only a single ground fault path and relay operation is not compromised.

### APPLICATION OF SINGLE GROUND ELECTRODE

A configuration sometimes used with four-wire dual-fed substations where only a 3-pole bus section CB is used is to use a single ground electrode connected to the mid-point of the neutral busbar in the switchgear, as presented in Figure 9. When operating with both incoming main circuit breakers and the bus section breaker closed, the bus section breaker must be opened first should the ground fault happen, in order to achieve discrimination. The co-ordination time between the ground fault relays  $R_F$  and  $R_E$  should be made at fault level  $F_2$  for a substation with both incoming supply breakers and bus section breaker closed.

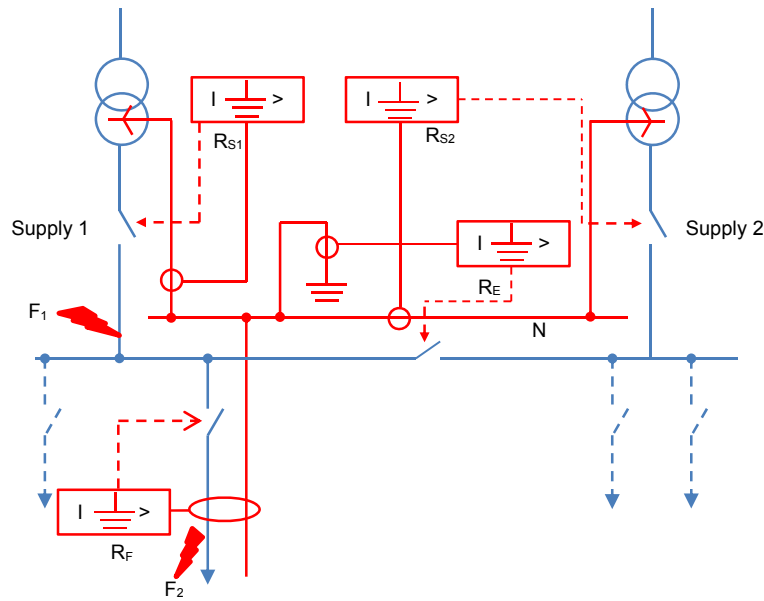

Figure 9. Dual fed four-wire systems: application of single point neutral grounding

When the substation is operated with the bus section switch closed and either one or both of the incoming supply breakers closed, it is possible for unbalanced neutral busbar load current to operate relay  $R_{S1}$  and/or  $R_{S2}$  and trip the incoming breaker. Interlocking the trip circuit of each  $R_S$  relay with typically closed auxiliary contacts on the bus section breaker can stop this. Nevertheless, should a ground fault happen on one side of the busbar when relays  $R_S$  are already operated, it is possible for a contact race to happen. When the bus section breaker opens, its break contact may close before the  $R_S$  relay trip contact on the healthy side can reset. Increasing the pick-up level of protection relays  $R_{S1}$  and  $R_{S2}$  above the maximum unbalanced neutral current may stop the tripping of both supply breakers. Nevertheless, the best option is to use 4-pole circuit breakers, and independently earth both sides of the busbar. If, during a busbar ground fault or uncleared feeder ground fault, the bus section breaker fails to open when needed, the interlocking break auxiliary contact will also be inoperative. This will stop protection relays  $R_{S1}$  and  $R_{S2}$  from functioning and providing back-up protection, with the result that the fault must be cleared by slower phase overcurrent protection relays. An optional method of finding back-up protection could be to install a second relay  $R_E$ , in series with protection relay  $R_E$ , having an operation time set longer than that of protection relays  $R_{S1}$  and  $R_{S2}$ . But since the extra relay must be set

to trip both of the incoming supply breakers, back-up protection would be accomplished but busbar selectivity would be lost.

## **INDUCTION MOTOR FAULT CURRENT CONTRIBUTION**

When an industrial system has motor loads, the motors will contribute fault current for a limited time. They contribute to the total fault current via the following mechanism. When an induction motor is operating, a flux, created by the stator winding, rotates at synchronous speed and interacts with the rotor. If a big reduction in the stator voltage happens for any reason, the motor flux cannot instantaneously change and the machine mechanical inertia will tend to inhibit speed reduction over the first few cycles of fault duration. The trapped flux in the rotor produces a stator voltage initially equal to the back e.m.f. induced in the stator before the fault and decaying. This is determined according to the X/R ratio of the related flux and current paths. Therefore, the induction motor acts as a generator resulting in a contribution of current whose AC and DC components exponentially decay. Typical 50Hz motor AC time constants lie in the range 10ms-60ms for LV motors and 60-200ms for HV motors. This motor contribution has often been ignored in the fault level calculations.

Industrial systems typically have a large motor load component, so this approach is not correct. Motor contributions to the total fault current may well be a major fraction of the total. Standards relating to fault level calculations, such as IEC 60909, demand that the motor contribution effect is included. Standards discuss the situations under which this should be done, and the calculation method to be used. Guidance is given on common motor fault current contribution for both HV and LV motors if the needed information is not known. Hence, it is now relatively easy, using adequate calculation software, to calculate the magnitude and duration of the motor contribution which enables a more accurate evaluation of the fault level for:

- relay co-ordination discrimination
- calculation of the needed switchgear/busbar fault rating

For protection calculations, motor fault level contribution is generally not an urgent issue. In industrial systems, fault clearance time is typically assumed to happen at 5 cycles after fault occurrence, and at this time, the motor fault level contribution is much

less than just after fault occurrence. In rare situations, it may have to be taken into account for correct time grading for through-fault protection considerations, and in the peak voltage calculation for high impedance differential protection configurations.

It is more important to take motor contribution into account when considering equipment fault rating (busbars, cables, switchgear, etc.). Typically, the initial AC motor current component at the instant of fault is of similar magnitude to the direct-on-line motor starting current. For LV motors, 5xFLC is assumed as the common fault current contribution (after considering the effect of motor cable impedance), with 5.5xFLC for HV motors, unless it is known that low starting current HV motors are installed. It is also common that similar motors connected to a busbar can be lumped together as one equivalent motor. In doing so, motor rated speed may need to be considered, as 2 or 4 pole motors have a longer fault current decay than motors with a higher number of poles. The kVA rating of the single equivalent motor is taken as the sum of the kVA ratings of the individual motors. It is still possible for motor contribution to be ignored in situations where the motor load on a busbar is insignificant in comparison to the total load (again IEC 60909 gives guidance in this respect). Nevertheless, big LV motor loads and all HV motors should be considered when calculating fault levels.

## **AUTOMATIC CHANGEOVER SYSTEMS**

Induction motors are typically used to drive critical loads. In some plants, such as those involving the pumping of fluids and gases, this has led to the need for a power supply control configuration in which motor and other loads are automatically transferred on loss of the normal supply to an optional supply. A fast changeover, allowing the motor load to be re-accelerated, decreases the possibility of a process trip happening. Such configurations are typically used for big generating units to transfer unit loads from the unit transformer to the station supply/start-up transformer. When the normal supply fails, induction motors that stay connected to the busbar slow down and the trapped rotor flux creates a residual voltage that exponentially decays. All motors connected to a busbar will start to decelerate at the same rate when the supply is lost if they stay connected to the busbar. This happens because the motors will exchange energy between themselves, so that they tend to stay 'synchronized' to each other.

Consequently, the residual voltages of all the motors decay at nearly the same rate. The magnitude of this voltage and its phase displacement with respect to the healthy alternative supply voltage is a function of time and the motor speed. The angular displacement between the residual motor voltage and the incoming voltage will be  $180^\circ$  at some instant. If the healthy back-up supply is switched on to motors which are running down under these conditions, very high inrush currents may happen, generating stresses which could be of adequate magnitude to cause mechanical stress, as well as a severe dip in the back-up supply voltage.

Two automatic transfer methods are applied:

- in-phase transfer system
- residual voltage system

The in-phase transfer method is presented in Figure 10(a). Normal and standby feeders from the same power source are used.

Phase angle measurement is applied to discover the relative phase angle between the standby feeder voltage and the motor busbar voltage. When the voltages are in phase or just prior to this condition, a high speed circuit breaker is used to complete the transfer. This approach is restricted to big high inertia drives where the gradual run down characteristic upon loss of normal feeder supply can be accurately anticipated. Figure 10(b) presents the residual voltage method, which is more typical, particularly in the petrochemical industry. Two feeders are used, feeding two busbar sections connected by a normally open bus section breaker. Each line is capable of transferring the total busbar load. Each bus section voltage is monitored and loss of supply on either section causes the relevant incomer CB to open. Given there are no protection operations to show the presence of a busbar fault, the bus section breaker is automatically closed to restore the supply to the unpowered busbar section of after the residual voltage created by the motors running down on that section has decreased to a an acceptable level.

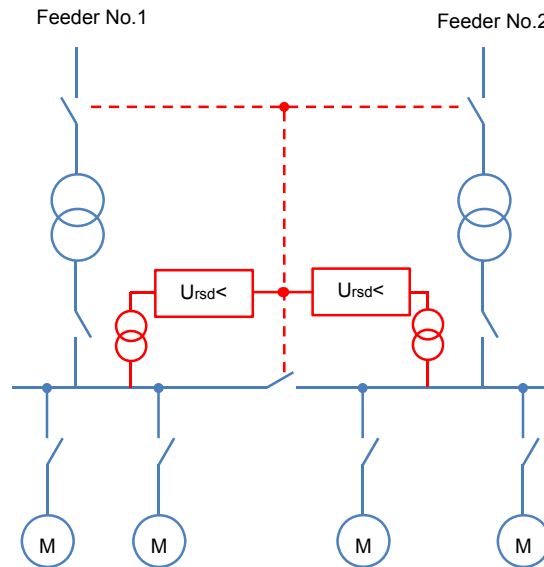
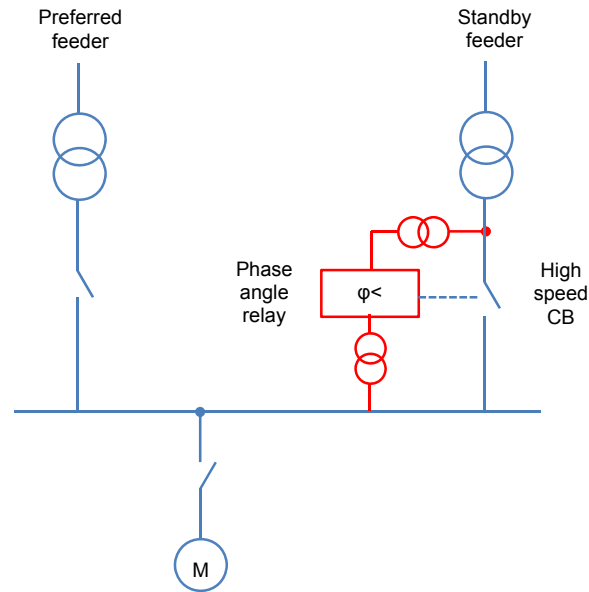

Figure 10. Auto-transfer systems (a) In phase transfer approach (b) Residual voltage approach

This is between 25% and 40%, of nominal voltage, dependent on the power system characteristics. The residual voltage setting selection will affect the re-acceleration current after the bus section breaker closes. For example, a setting of 25% may be anticipated to result in an inrush current of around 125% of the starting current at full voltage. Optionally, a time delay could be used as a residual voltage measurement substitute, which would be set with knowledge of the plant to make sure that the residual voltage would have sufficiently decreased before transfer is started. The protection relay settings for the switchboard must take account of the total load current

and the voltage dip during the re-acceleration period in order to avert spurious tripping during this time. This time can be few seconds where big inertia HV drives are used.

## **VOLTAGE AND PHASE REVERSAL PROTECTION**

Voltage protection relays have been widely used in industrial power supply systems. The principle detects under-voltage and/or overvoltage conditions at switchboards and disconnects supplies before damage happens. Continued overvoltage may create damage to voltage-sensitive devices (e.g. electronics), while under-voltage may create excessive current to be taken by motor loads. Motors are equipped with thermal overload protection to avert excessive current damage, but under-voltage protection is typically used to disconnect motors after a prolonged voltage dip. With a voltage dip made by a source system fault, a group of motors could decelerate to such a degree that their aggregate reacceleration currents might keep the recovery voltage depressed to a level where the motors might stall. Modern numerical motor protection relays usually contain voltage protection functions, therefore removing the need for discrete under-voltage protection relays. Previous installations may still utilize discrete under-voltage protection relays, but the setting criteria stay the same.

Reverse phase sequence voltage protection should be used where it may be difficult for a motor to be started with rotation in the opposite direction. Incorrect rotation due to reverse phase sequence might be set up following error after power system maintenance or repairs. Older motor control switchboards might have been equipped with discrete protection relays to discover this condition. Modern motor protection relays may use this function. If reverse phase sequence is discovered, motor starting can be stopped. If reverse phase sequence voltage protection is not given, the high-set negative phase sequence current protection in the protection relay would promptly discover the condition once the starting device is closed – but motor initial reverse rotation could not be stopped.



## POWER FACTOR CORRECTION AND CAPACITOR PROTECTION

Loads such as induction machines take substantial reactive power from the supply system. This may end with poor power factor. The reactive power flow increases the voltage drops through series reactances such as transformers and reactors. It takes some of the power system plant current carrying capacity and it increases the power system resistive losses. To offset the losses and restrictions in plant capacity, utilities typically apply tariff penalties to big industrial or commercial customers for running their plant at low power factor. Therefore, the customer is stimulated to improve the system power factor and it may be efficient to install fixed or variable power factor correction equipment. These devices will increase or regulate the plant power factor. Shunt capacitors are typically used to improve power factor. The basis for reactive power compensation is presented in Figure 11, where  $\angle\phi_1$  represents the uncorrected power factor angle and  $\angle\phi_2$  the angle relating to the desired power factor.

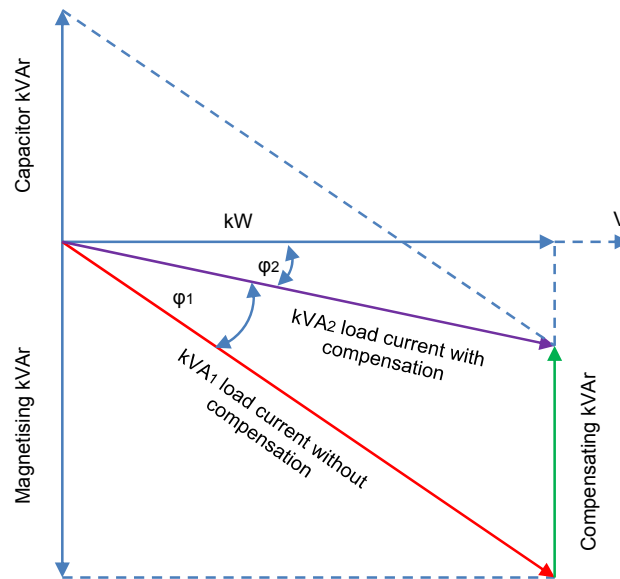

Figure 11. Power factor correction method

The following may be concluded from this vector diagram:

$$\text{Uncorrected power factor} = \frac{kW}{kVA_1} = \cos \angle\phi_1$$

$$\text{Corrected power factor} = \frac{kW}{kVA_2} = \cos \angle\phi_2$$

$$\text{Reduction in } kVA = kVA_1 - kVA_2$$

If the kW load and uncorrected power factors are known, then the capacitor rating to accomplish a given degree of correction may be computed from:

$$\text{Capacitor } kVAr = kW \times (\tan \angle\phi_1 - \tan \angle\phi_2)$$

A spreadsheet can easily be made to compute the required amount of compensation to accomplish a desired power factor.

### **CAPACITOR CONTROL**

Where the plant load or the plant power factor drastically changes, it is mandatory to control the power factor correction. Otherwise, over-correction will end in excessive system voltage and unnecessary losses. In several industrial systems, capacitors are manually switched in when needed, but automatic controllers are standard practice. A controller gives automatic power factor correction, by comparing the running power factor with the target power factor. Based on the available groupings, an adequate amount of capacitance is switched in or out to keep an optimum average power factor. The controller is equipped with a 'loss of voltage' relay element to make sure that all selected capacitors are instantaneously disconnected if there is a supply voltage interruption. When the supply voltage is fixed, the capacitors are progressively reconnected as the plant starts up. To make sure that capacitor groups degrade at approximately the same rate, the controller typically rotates selection or randomly chooses groups of the same size in order to even out the connected time. The installation of overvoltage protection to trip the capacitor bank is also needed in particular applications. This would be to stop a serious system overvoltage if the power factor correction (PFC) controller fails to take quick corrective action. The PFC design must recognize that many industrial loads create harmonic voltages, with the result that the PFC capacitors may sink substantial harmonic currents. A harmonic study may be required to decide the capacitor thermal ratings or whether series filters are needed.

## **MOTOR P.F. CORRECTION**

When dealing with motor load power factor correction, group correction is not the most economical method. Some industrial consumers use capacitors to chosen motor substations rather than using all of the correction at the main incoming substation busbars. Frequently, power factor correction may even be applied to individual motors, ending in optimum power factor being achieved under all conditions of aggregate motor load. In some situations, the improvement in the voltage regulation can also improve motor starting. Motor capacitors are usually six-terminal units, and a capacitor may be installed directly across each motor phase winding. Capacitor sizing is crucial, such that a leading power factor does not happen under any load condition. If extra capacitance is applied to a motor, it may be possible for self-excitation to happen when the motor is switched off or experiences a supply failure. This can result in the generation of a high voltage or in mechanical damage if there is a sudden supply restoration. Since most star/delta or auto-transformer starters involve a transitional break in supply, it is typically suggested that the capacitor rating should not surpass 85% of the motor magnetizing reactive power.

## **CAPACITOR PROTECTION**

When considering capacitor protection, provision should be made for the transient inrush current happening on switch-on, since this can reach peak values of around 20 times normal current. Capacitor switchgear is typically substantially de-rated to allow for this. Inrush currents may be fixed by a resistor in series with each capacitor or capacitor banks. Protection equipment is needed to stop rupture of the capacitor due to an internal fault and also to protect the cables and related devices from damage in case of a capacitor failure. If fuse protection is contemplated for a three-phase capacitor, HRC fuses should be used with a current rating of not less than 1.5 times the rated capacitor current. Medium voltage capacitor banks can be protected by the configuration presented in Figure 13. Since harmonics increase capacitor current, the protection relay will react more correctly if it does not have in-built tuning for harmonic rejection. Double star capacitor banks are used at medium voltage. As presented in Figure 12, a current transformer in the inter star-point connection can be used to drive a protection relay to discover the out-of-balance currents that will run when capacitor elements become short-circuited or open-circuited. The protection relay will have

adjustable current settings, and it might have a bias circuit, supplied from an external voltage transformer, that can be adjusted to compensate for steady-state spill current in the inter star-point connection.

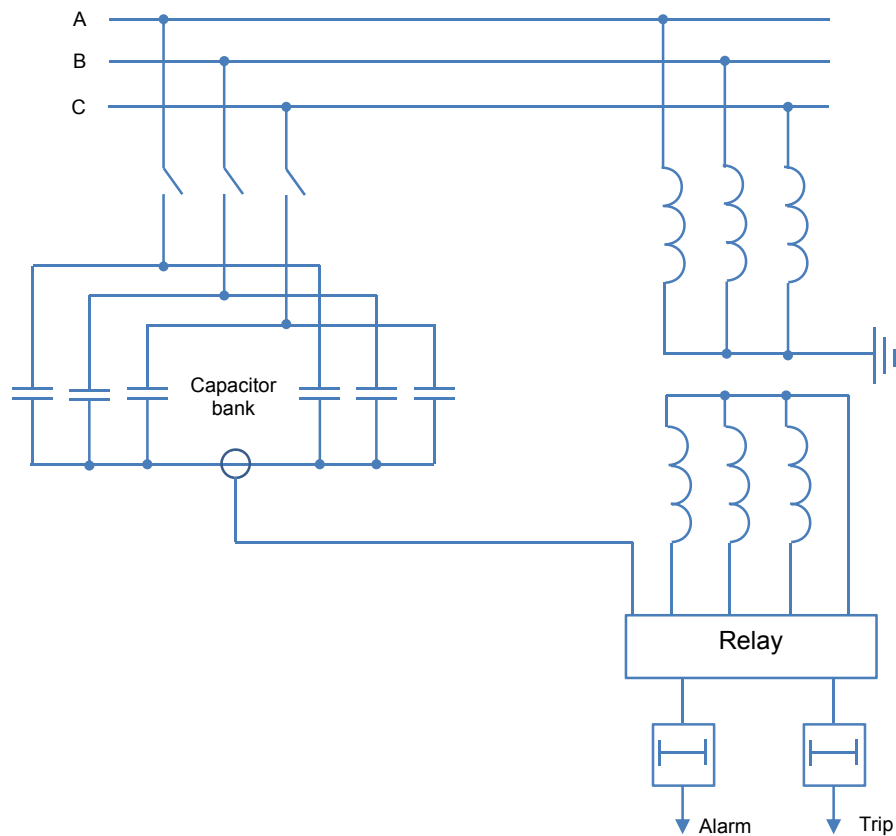

Figure 12. Double star capacitor bank protection

Some industrial loads such as arc furnaces require large inductive components and correction is usually provided using very large, high voltage capacitors in different arrangements. Another high voltage capacitor arrangement is the 'split phase' configuration where the elements making up each phase of the capacitor are separated into two parallel paths. Figure 14 presents two possible relay connection arrangements. A differential protection relay can be used with a current transformer for each parallel branch. The protection relay compares the current in the split phases, using sensitive current settings but also adjustable compensation for the unbalance currents arising from initial capacitor mismatch.

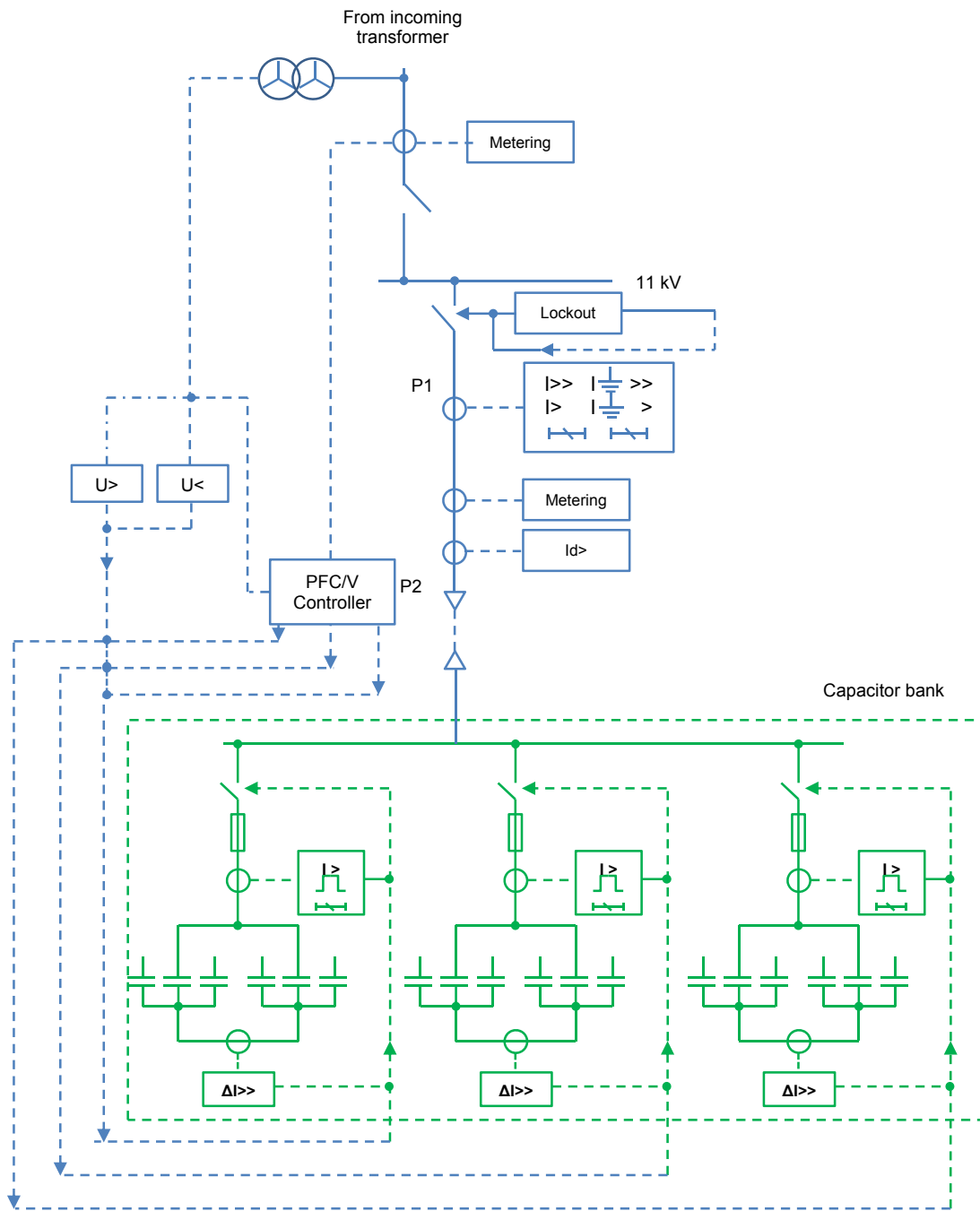

Figure 13. Capacitor bank protection

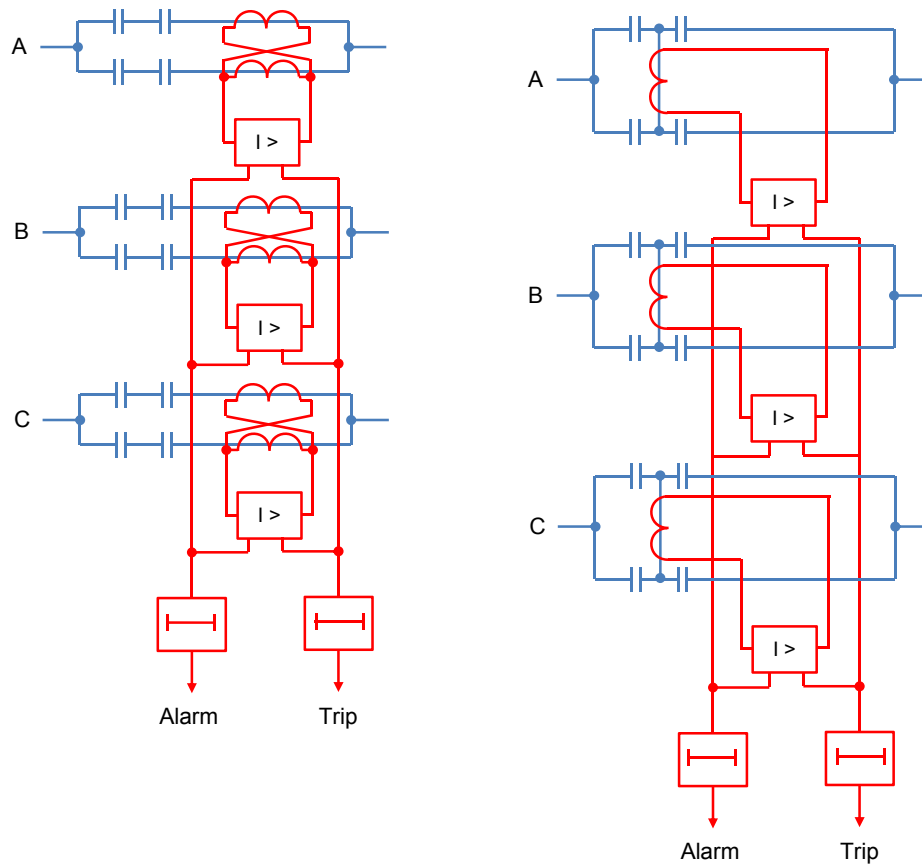

Figure 14. Split phase capacitor bank differential protection

## EXAMPLES

In next paragraphs, examples of the industrial system protection are presented.

## FUSE CO-ORDINATION

Fuse application example is based on the configuration presented in Figure 15(a). This presents an unsatisfactory configuration with frequently encountered shortcomings. It can be noted that fuses B, C and D will discriminate with fuse A but the 400A sub-circuit fuse E may not discriminate, with the 500A sub-circuit fuse D at higher levels of fault current.

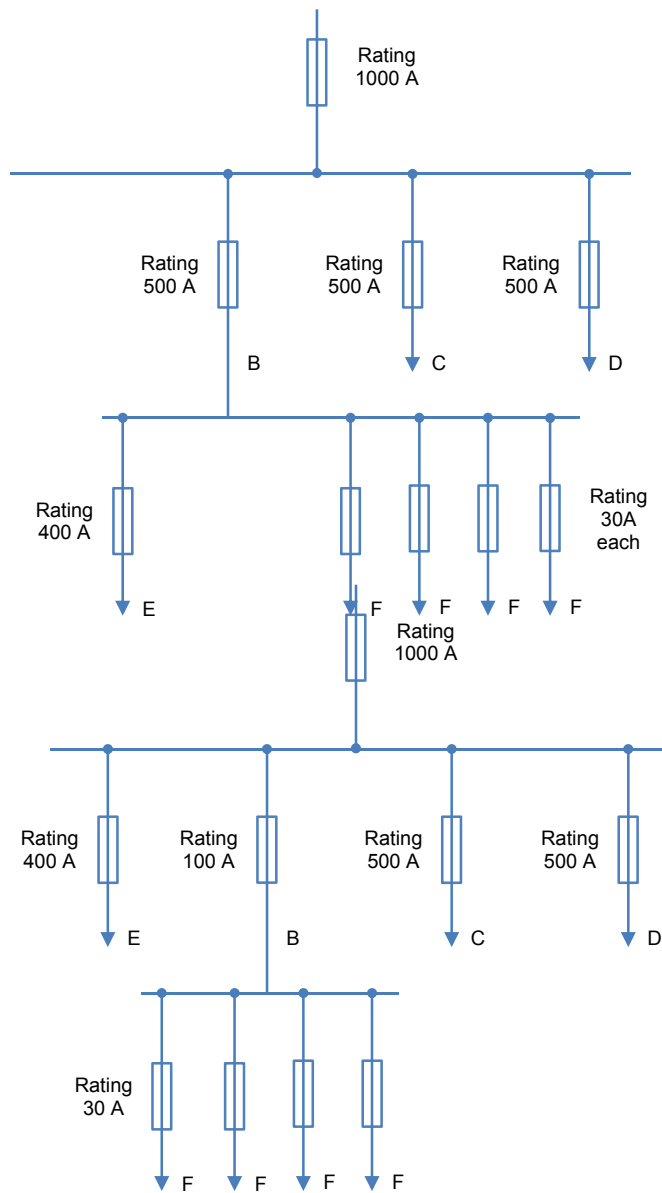

Figure 15. Fuse protection: effect of layout on discrimination (a) Incorrect applications increasing discrimination problem in (b) Correct application and discrimination

The solution, presented in Figure 15(b), is to supply the 400A circuit E direct from the busbars. The sub-circuit fuse D may now have its rating decreased from 500A to a value, of approximately 100A, adequate to the remaining sub-circuit. This configuration now gives a satisfactory discriminating fuse distribution scheme. Nevertheless, there are industrial applications where discrimination is a secondary issue. In the application presented in Figure 16, a contactor having a fault rating of 20kA controls the load in one sub-circuit. A fuse rating of 630A is chosen for the minor

fuse in the contactor circuit to provide protection within the contactor through-fault capacity.

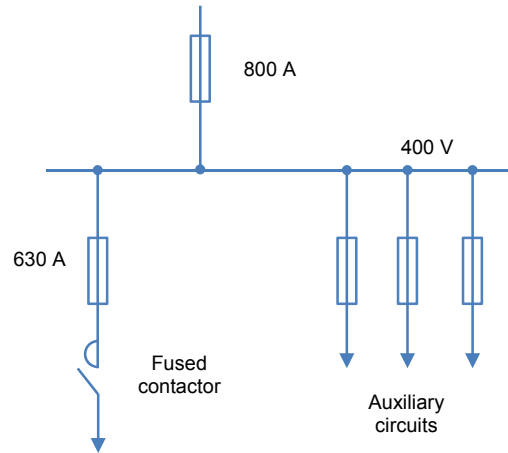

Figure 16. Back-up protection example

The major fuse of 800A is selected, as the minimum rating that is higher than the total load current on the switchboard. Discrimination between the two fuses is not achieved, as the pre-arcing  $I^2t$  of the 800A fuse is less than the total  $I^2t$  of the 630A fuse. Hence, the major fuse will blow as well as the minor one, for most faults so that all other loads supplied from the switchboard will be lost. This may be allowable in some situations. Nevertheless, in most situations loss of the complete switchboard for a fault on a single outgoing circuit will not be acceptable, and the design will have to be changed.

### **FUSES/MCCBS/OVERCURRENT RELAYS GRADING**

Configuration example involving a molded case circuit breaker, fuse and a protection relay is presented in Figure 17. A 1MVA 3.3kV/400V transformer supplies the LV board via a circuit breaker, which is equipped with numerical relay that has a setting range of 8-400% of rated current and supplied from 2000/1A CTs.



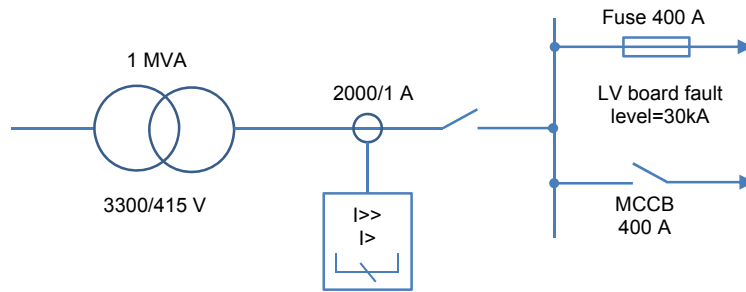

Figure 17. Protection co-ordination example network diagram– fuse/MCCB/relay

Discrimination is needed between the protection relay and both the fuse and MCCB up to the 40kA fault rating of the board. To start with, the time/current characteristics of both the 400A fuse and the MCCB are printed in Figure 18.

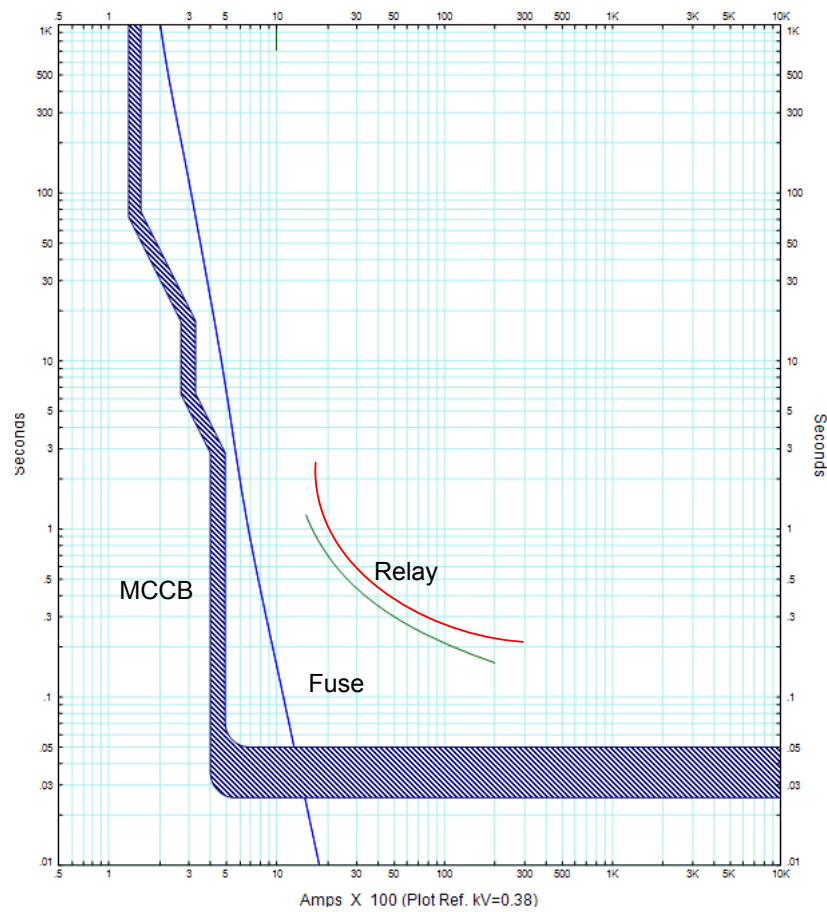

Figure 18. Fuse/MCCB/relay grading curves

## DETERMINATION OF RELAY CURRENT SETTING

The selected relay current setting must not be lower than the full load current level and must have sufficient margin to allow the relay to reset with full load current running. Full load current can be calculated from the transformer rating:

$$FCL = \frac{kVA}{kV \times \sqrt{3}} = \frac{1000}{0.4 \times \sqrt{3}} = 1443 A$$

With the CT ratio of 2000/1A and a protection relay reset ratio of 95% of the nominal current setting, a current setting of at least 80% would be sufficient, to avoid tripping and/or failure to reset with the transformer transferring full load current. Nevertheless, value selection at the lower end of this current setting range would shift the relay characteristic towards that of the MCCB and discrimination may be lost at low fault currents. Hence, it is prudent to initially choose a protection relay current setting of 100%.

## RELAY CHARACTERISTIC AND TIME MULTIPLIER SELECTION

An EI characteristic is chosen for the protection relay to ensure discrimination with the fuse. From Figure 18, it may be noted that at the fault level of 40kA the fuse will operate in less than 0.01s and the MCCB operates in roughly 0.014s. Applying a fixed grading margin of 0.4s, the demanded relay operating time becomes  $0.4 + 0.014 = 0.414s$ . With a CT ratio of 2000/1A, a protection relay current setting of 100%, and a protection relay TMS setting of 1.0, the extremely inverse curve provides a relay operating time of 0.2s at a fault current of 40kA. This is too fast to provide sufficient discrimination and shows that the EI curve is too severe for this application. Turning to the VI protection relay characteristic, the relay operation time is around 0.71s at a TMS of 1.0. To reach the demanded relay operating time of 0.414s:

$$TMS \text{ setting} = \frac{0.414}{0.71} = 0.583$$

Use a TMS of 0.6, nearest possible setting. The use of a different form of inverse time characteristic makes it advisable to verify discrimination at the lower current levels also at this stage. At a fault current of 4kA, the protection relay will trip in 8.1s, which does not provide discrimination with the MCCB. A protection relay operation time of 8.3s is needed. To resolve this, the protection relay characteristic has to be moved away from

the MCCB characteristic, a modification that may be accomplished by using a TMS of 0.625. The revised protection relay characteristic is also presented in Figure 18.

### DUAL-FED SUBSTATION PROTECTION

Numerical protection relays can be used in an industrial system. Consider the common large industrial substation presented in Figure 19. Two 1.6MVA, 11/0.4kV transformers supplying a busbar whose bus-section CB is typically open. The LV system is solidly grounded. The largest outgoing feeder is to a motor rated 160kW, 193kVA, and a starting current of 7 x FLC.

The transformer impedance is to IEC standards. The LV switchgear and bus bars are fault rated at 50kA rms. To simplify the assessment, only the phase-fault LV protection is looked at.

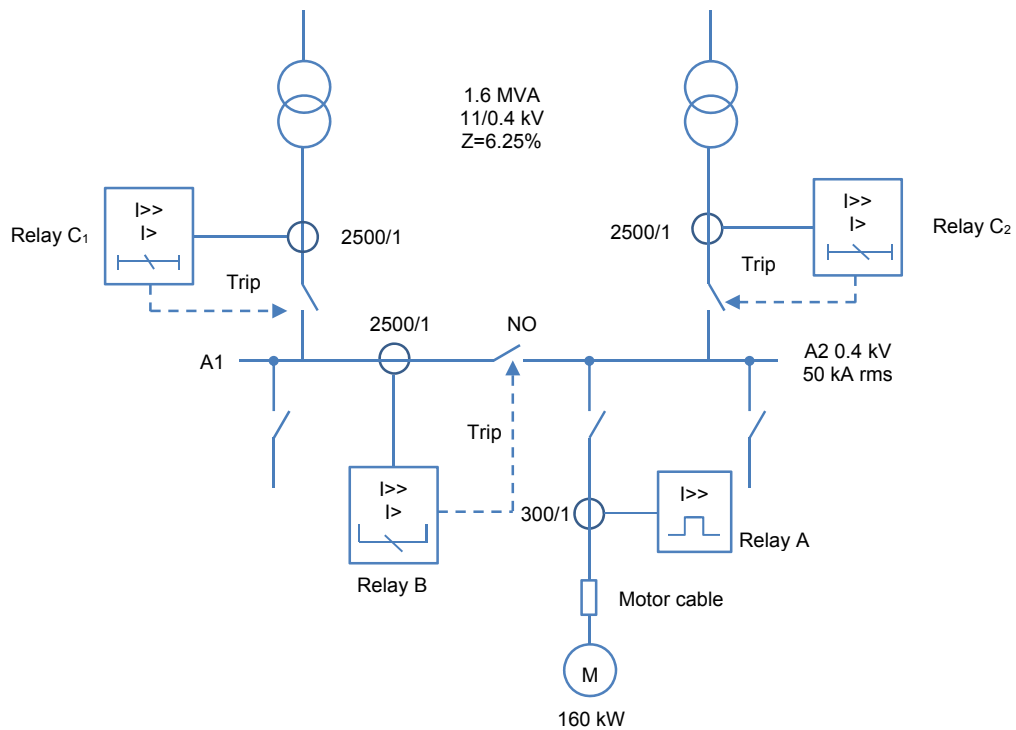

Figure 19. Dual-fed switchboard relay grading example

## **GENERAL CONSIDERATIONS**

Assessment of many substations organized as in Figure 19 indicates that the maximum fault level and feeder load current is got with the bus-section circuit breaker closed and one of the infeeding CBs open. This is valid so long as the switchboard has a considerable amount of motor load. The motor load contribution to the switchboard fault level is typically higher than that from a single infeeding transformer, since the transformer restricts the amount of fault current infeed from the primary side. The three-phase break fault level at the switchboard under these conditions is assumed to be 40kA rms. Relays C do not need to have directional characteristics as all three circuit breakers are only momentarily closed during transfer from a single infeeding transformer to two infeeding transformers arrangement. This transfer is typically an automated sequence, and the chance of a fault happening during the short period (of the order of 1s) when all three CBs are closed is taken to be negligibly small. Even though this arrangement gives the highest fault level at the switchboard, it is not considered from either a switchboard fault rating or protection viewpoint. It is assumed that modern numerical protection relays are installed. For simplicity, a fixed grading margin of 0.3s is applied.

## **MOTOR PROTECTION RELAY SETTINGS**

From the provided motor characteristics, the overcurrent protection relay settings (Relay A) can be found as follows:

Thermal element:

- current setting: 300A
- time constant: 20 mins

Instantaneous element:

- current setting: 2.32kA

These are the only settings relevant to the upstream protection relays.

## **RELAY B SETTINGS**

Relay B settings are found from consideration of the loading and fault levels with the bus-section breaker between busbars A1 and A2 closed. No data is provided about the load split between the two busbars, but it can be assumed in the absence of

definitive information that each busbar is capable of feeding the total load of 1.6MVA. With fixed tap transformers, the bus voltage may decrease to 95% of nominal under these conditions, leading to a load current of 2430A. The IDMT current setting must be higher than this, to avert relay operation on normal load currents and with aggregate starting/re-acceleration currents. If the complete load on the busbar was motor load, an aggregate starting current in excess of 13kA would happen, but a current setting of this order would be too high and lead to further upstream grading problems. It is unlikely that the complete load is motor load (though this does happen, especially where a supply voltage of 690V is selected for motors – an increasingly typical practice) or that all motors are simultaneously started (but simultaneous re-acceleration may well happen). What is basic is that protection relay B does not issue a trip command under these conditions – i.e. the protection relay current/time characteristic is in excess of the current/time characteristic of the worst-case starting/reacceleration condition. Therefore, it is assumed that 50% of the total bus load is motor load, with an average starting current of 600% of full load current (= 6930A), and that re-acceleration takes 3s. Therefore, a current setting of 3000A is initially applied. The SI characteristic is used for grading the protection relay, as coordination with fuses is not needed. The TMS is needed to be set to grade with the thermal protection of protection relay A under 'cold' conditions, as this provides the longest operation time of Relay A, and the re-acceleration conditions. A TMS value of 0.41 is found to give satisfactory grading, being dictated by the motor starting/re-acceleration transient. Adjustment of both current and TMS settings may be needed depending on the exact re-acceleration circumstances. Note that lower current and TMS settings could be applied if motor starting/reacceleration did not need to be considered.

The high-set setting has to be above the full load current and motor starting/re-acceleration transient current, but less than the fault current by a suitable margin. A setting of 12.5kA is initially chosen. A time delay of 0.3s has to be applied to make sure grading with relay A at high fault current levels; both protection relays A and B may detect a current in excess of 25kA for faults on the cable side of the CB supplying the 160kW motor. The protection relay curves are presented in Figure 20.

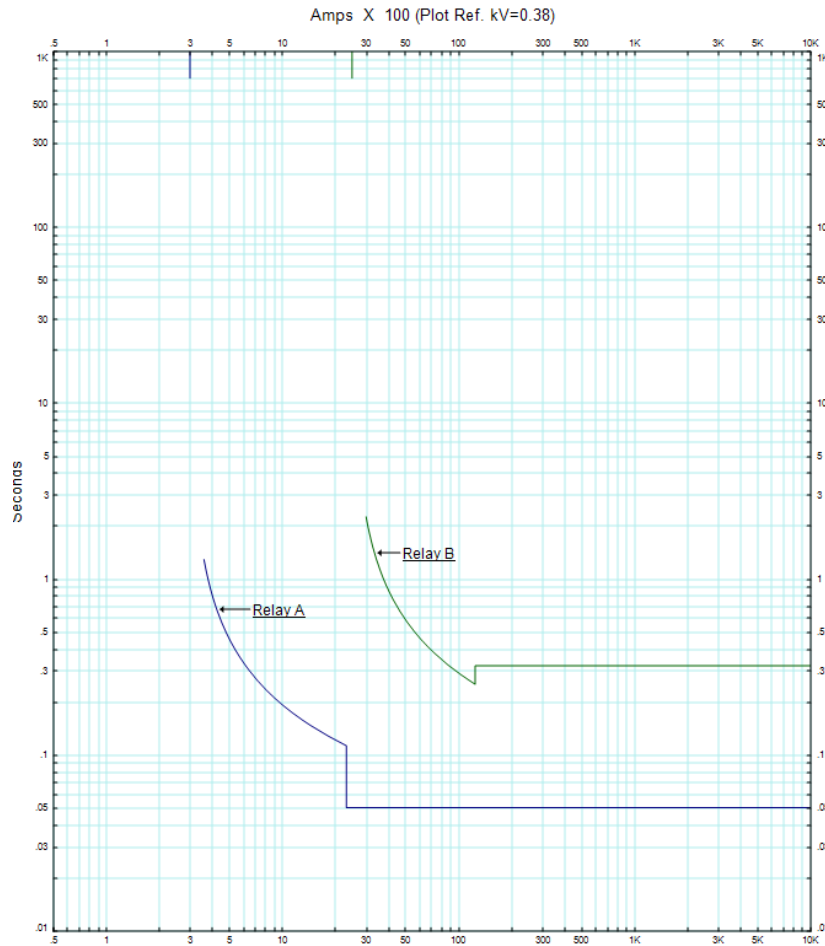
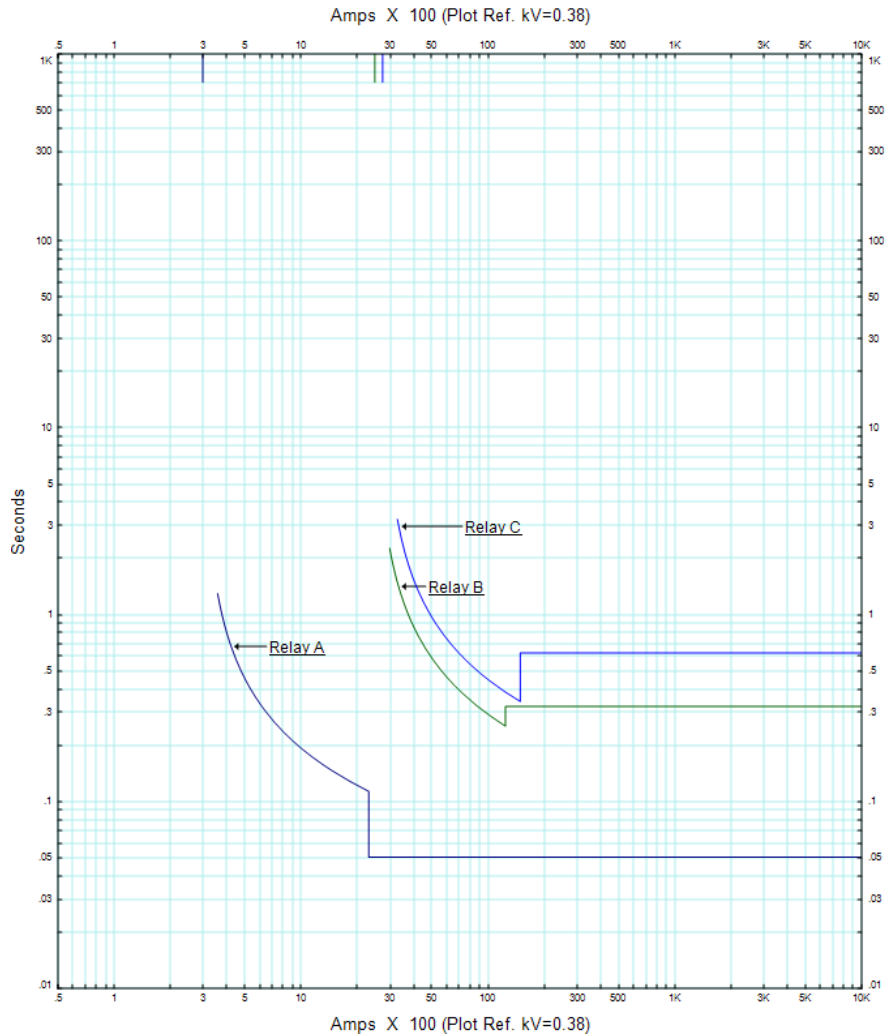

Figure 20. Relay A and B grading

### RELAYS C SETTINGS

The setting of the IDMT element of protection relays C1 and C2 has to be adequate for protecting the busbar while grading with protection relay B. The limiting condition is grading with protection relay B, as this provides the longest operation time for protection relays C. The current setting has to be above that for protection relay B to accomplish full co-ordination, and a value of 3250A is suitable. The TMS setting using the SI characteristic is selected to grade with that of protection relay B at a current of 12.5kA (protection relay B instantaneous setting), and is found to be 0.45. The high-set element must grade with that of protection relay B, so a time delay of 0.62sec is needed. The current setting must be greater than that of relay B, so use a value of 15kA. The final protection relay grading curves and settings are presented in Figure 21.



	Parameter	Value	Parameter	Value	Parameter	Value	Parameter	Value
Relay A	I <sub>th</sub>	300A	Time const.	1200s	I <sub>&gt;&gt;</sub>	2320A	T <sub>inst</sub>	0
Relay B	I <sub>&gt;</sub>	2500A	TMS	0.175	I <sub>&gt;&gt;</sub>	12500A	T <sub>inst</sub>	0.32s
Relay C	I <sub>&gt;</sub>	2750A	TMS	0.25	I <sub>&gt;&gt;</sub>	15000	T <sub>inst</sub>	0.62s

Figure 21. Final relay grading curves

### COMMENTS ON GRADING

While the above grading may seem satisfactory, the transformer primary side protection has not been assessed. IDMT protection at this point will have to grade with protection relays C and with the transformer and cabling through-fault short-time withstand curves. This may end in overly long operation times. Even if the operation time at the 11kV level is acceptable, there is probably a utility infeed to consider, which will require an additional set of protection relays and another stage of time grading, and the fault clearance time at the utility infeed will almost certainly be excessive. One

solution is to allow a total supply loss to the 0.4kV bus under conditions of a single infeed and bus section CB closed. This is accomplished by setting protection relays C such that grading with protection relay B does not happen at all current levels, or omitting protection relay B from the protection configuration. The argument for this is that network operation policy is to ensure loss of supply to switchboard both sections does not happen for single contingencies. As single infeed operation is not normal, a contingency has already happened, so that an additional fault causing total supply loss to the switchboard through tripping of one of protection relays B is a second contingency. Therefore, total loss of supply is acceptable. The alternative is to allow a lack of discrimination at some point on the system. Another solution is to use partial differential protection to remove the requirement for Relay A, but this is rarely used. The used strategy will depend on the particular conditions.